

Pillow blocks Eccentric locking collar type

MUP000 type

MUP000C(E) type

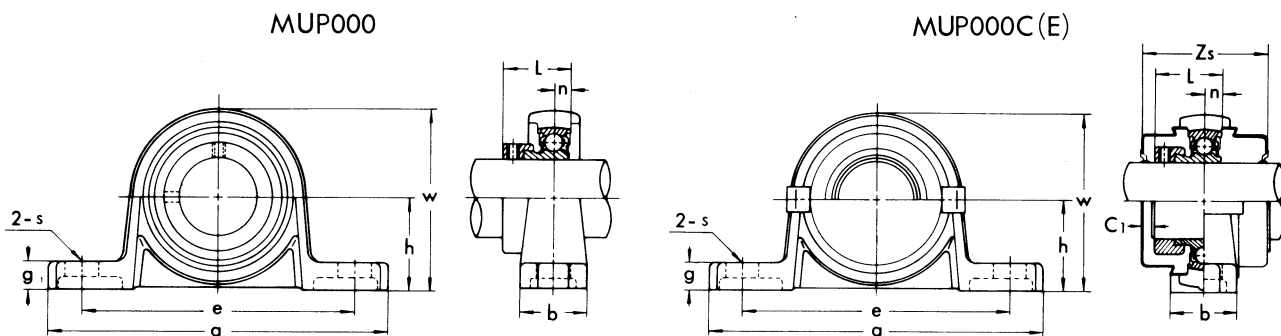

Shaft dia. (mm)	Unit No.	Dimensions (mm)											Mounting bolt size
		h	a	e	b	s	g	w	L	n	C ₁	Z _s	
10	MUP000	18	67	53	16	7	6	35	17.5	4	2	33	M 6
12	MUP001	19	71	56	16	7	6	38	17.5	4	2	33	M 6
15	MUP002	22	80	63	16	7	7	43	18.5	4.5	2	34	M 6
17	MUP003	24	85	67	18	7	7	47	20.5	5	2	38	M 6
20	MUP004	28	100	80	20	10	9	55	24.5	6	3	46	M 8
25	MUP005	32	112	90	20	10	10	62	25.5	6	3	47	M 8
30	MUP006	36	132	106	26	13	11	70	26.5	6.5	4	50	M10

Bearing No.	Bearing		Housing No.	Unit No. with covers	Stainless steel cover No.		Weight (g)		
	Basic load rating (kgf) (1 kgf=9.8N)				Open(closed)	Open	Closed	Normal	With cover
	Cr	Cor							
MU000+ER	400	160	P000Z3	MUP000C(E)	000CP10	000CPE	77	85	
MU001+ER	440	195	P001Z3	MUP001C(E)	001CP12	001CPE	91	100	
MU002+ER	485	230	P002Z3	MUP002C(E)	002CP15	002CPE	125	135	
MU003+ER	520	270	P003Z3	MUP003C(E)	003CP17	003CPE	156	170	
MU004+ER	810	410	P04-5Z3	MUP004C(E)	04-5CP20	04-5CPE	230	250	
MU005+ER	875	475	P05-6Z3	MUP005C(E)	05-6CP25	05-6CPE	294	315	
MU006+ER	1150	675	P06-7Z3	MUP006C(E)	06-7CP30	06-7CPE	454	480	

Materials

Series	SILVER	STAINLESS SILVER
Unit No.	UP000, UFL000 UP000C(E), UFL000C(E)	MUP000, MUFL000 MUP000C(E), MUFL000C(E)
Bearing	High carbon chromium bearing steel(SUJ2)	Stainless steel (SUS440C)
Rubber seal	NBR	
Eccentric locking collar	Carbon steel for machine structure (SxxC) or Rolled steel for general structure (SS)	
	Black oxide treatment	Electro plated (MFCr)
Housing	Zinc alloy die-casting (ZDC)	
	—	Electro plated (MZCr)
Stainless steel cover	Stainless steel (SUS430)	

Limiting speed

